

# A40T

## Ultra-Compact Two-Way On-Wall System – Transformer

# ADORN

### Features

- Contemporary, unobtrusive design
- High output capability
- High fidelity sound
- Low and high-frequency overload protection
- 70V/100V line transformer
- Vertical or horizontal orientation
- Wide 110° x 80° coverage
- Wall bracket included
- 5-year warranty

### Applications

- Retail outlets
- Cafes, bars and restaurant chains
- Hotels and convention centres
- Educational facilities
- Corporate offices



The A40T is a two-way passive speaker with an elegant design that is perfect for architectural environments that require high-fidelity sound from an unobtrusive, ultra-compact enclosure. It brings class-leading performance, reliability and value to a wide range of commercial sound applications — from retail outlets, bars and restaurants to corporate offices and convention centres.

The A40T is the perfect choice for background and foreground systems which require superior performance. Its Martin Audio signature sound characteristic also provides a seamless sonic transition within a multi-zoned complex using larger Martin Audio systems such as CDD or BlacklineX.

Comprising a 4" (100mm) LF driver and a 0.75" (19mm) silk-dome HF driver on a 110° x 80° horn, it handles 40W AES, 160W peak and can produce 109dB peak output at 1 metre. It has a smooth frequency response and strong bass reproduction that extends down to 70Hz.

The A40T incorporates a high-quality transformer for 70V/100V line operation, with transformer taps selected by a rotary switch.

The recommended amplifier is the VIA5002 in conjunction with a suitable line transformer. For full-bandwidth protection, the low and high-frequency sections are individually protected against overload.

Available in black or white as standard, it can be readily painted to match any décor, and can be wall-mounted vertically or horizontally using the wall bracket supplied. In addition, for general outdoor use the cabinet only requires the additional waterproof connector cover.

The VIA5002 amplifier in combination with a Martin Audio DX0.5 controller will be perfect partners for small scale efficient installations, or with the DX4.0 controller for larger more complex installations, which could then also be managed by Martin Audio's VU-NET control software platform.

The Martin Audio SX110 subwoofer will extend the bandwidth of ADORN on-wall speakers and is ideal for foreground music applications which require increased impact and low frequency performance.

# A40T

## Ultra-Compact Two-Way On-Wall System – Transformer

**ADORN**

### Technical Specifications

TYPE	Ultra-compact passive two-way system, front ported bass reflex
FREQUENCY RESPONSE (1)	98Hz-17kHz ± 3dB -10dB @ 70Hz
DRIVERS	LF: 4" / 1" high-temp voice coil, coated paper cone, rubber surround, ferrite motor, pressed steel chassis HF: 0.75" silk dome, neodymium motor
RATED POWER (2)	40W AES, 160W peak
RECOMMENDED AMPLIFIER	VIA 5002 [In conjunction with suitable line transformer]
SENSITIVITY (1)	87dB/1W/1m
MAXIMUM SPL (9)	109dB peak
NOMINAL IMPEDANCE	16 ohms
DISPERSION (-6dB)	110° H x 80° V
CROSSOVER	3.5kHz passive (LF and HF auto-resetting fuses)
TRANSFORMER TAPS	70V: 20w / 10w / 5w / 2.5w 100V: 20w / 10w / 5w
RECOMMENDED HIGH-PASS FILTER	60Hz 24dB/oct
ENCLOSURE	ABS, UL 94V-0 rated
FINISH	Black or white
GRILLE	Perforated steel
CONNECTORS	Push terminals
FITTINGS	Wall bracket included
DIMENSIONS EXCL. BRACKET	(W) 124mm x (H) 200mm x (D) 114mm (W) 4.9in x (H) 7.9in x (D) 4.5in
WEIGHT	2.13kg (4.7lbs)
ACCESSORIES	Waterproof connector cover

**Notes**

- (1) Measured on-axis in half (2pi) space at 2 metres, then referred to 1 metre.
- (2) AES Standard ANSI S4.26-1984.
- (3) Measured in half (2pi) space at 2 metres with 1 watt input, using band limited pink noise, then referred to 1 metre.
- (4) Measured in half (2pi) space at 2 metres using band limited pink noise, then referred to 1 metre.
- (5) Measured on-axis in open (4pi) space at 2 metres, then referred to 1 metre.
- (6) Measured in open (4pi) space at 2 metres with 1 watt input, using band limited pink noise, then referred to 1 metre.
- (7) Measured in open (4pi) space at 2 metres using band limited pink noise, then referred to 1 metre.
- (8) Measured in open (4pi) space at 2 metres with 2.83v input, using band limited pink noise, then referred to 1 metre.
- (9) Calculated at 1 metre.
- (10) Measured in half (2pi) space at 2 metres with 2.83V input, using band limited pink noise, then referred to 1 metre.

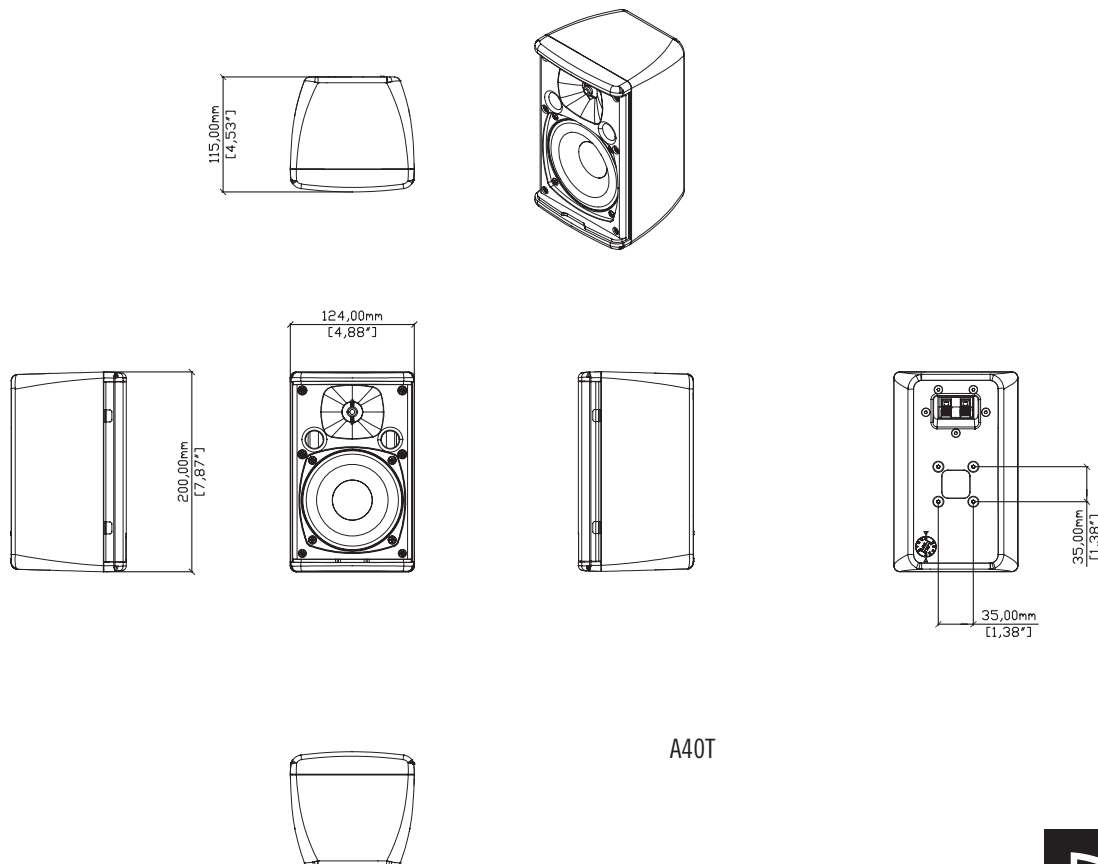

Martin Audio Ltd  
 Century Point, Halifax Road, High Wycombe  
 Buckinghamshire HP12 3SL, England

Telephone: +44 (0) 1494 535 312  
 Facsimile: +44 (0) 1494 438 669  
 Email: info@martin-audio.com

