

ALLEN & HEATH

Allen & Heath Limited
 Kernick Industrial Estate
 Penryn, Cornwall,
 TR10 9LU, UK
www.allen-heath.com

DT168 Technical Datasheet

Overview

- 16 Mic Preamps on XLR
- Phantom Power LED per Input
- 8 XLR Line Outs
- Dante Primary connection with locking Ethercon port
- Dante Secondary locking Ethercon port for daisy chaining or redundancy
- Rubber bumpers
- Carry handle
- Optional rack mount kit available

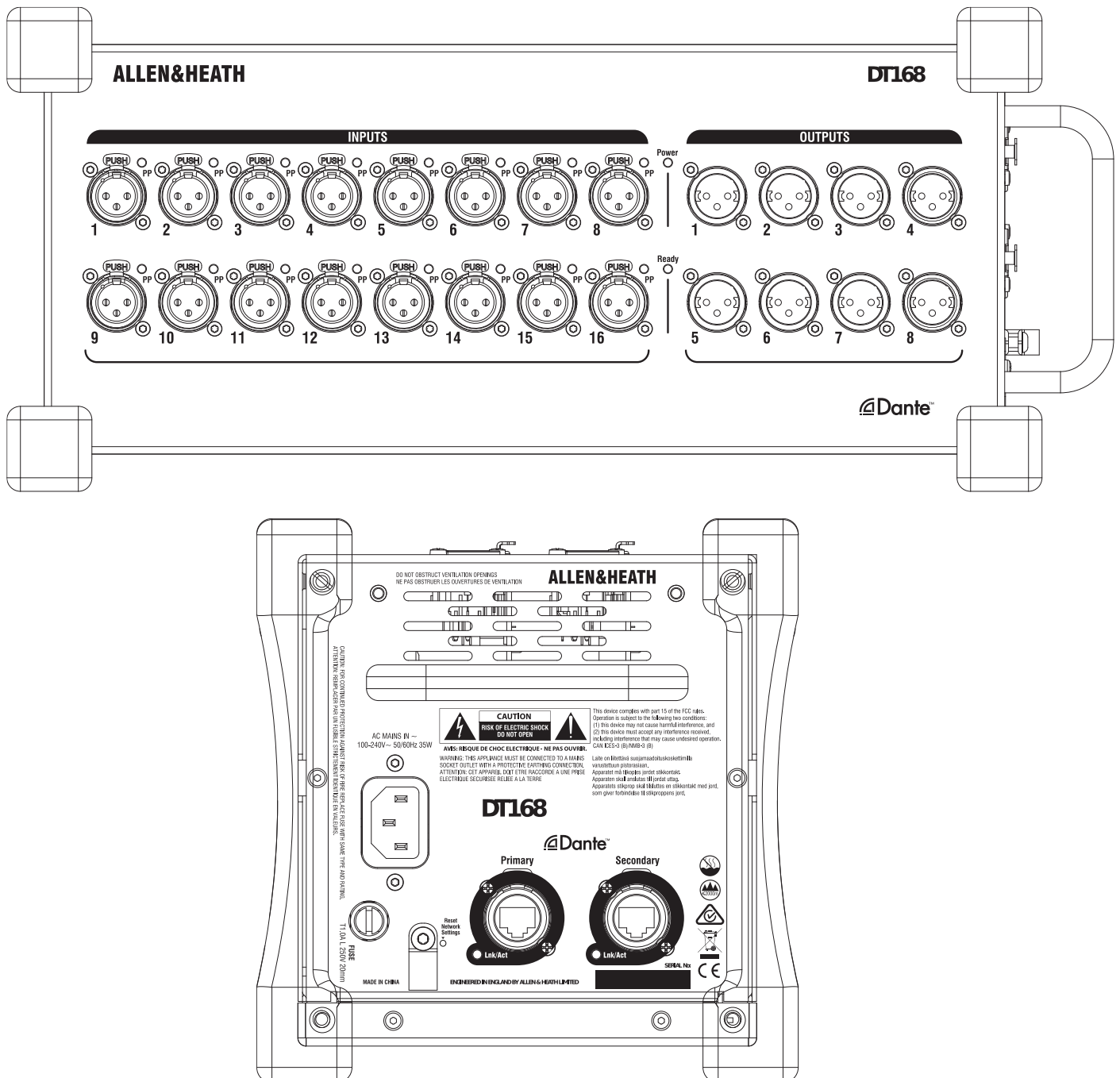

Dimensions

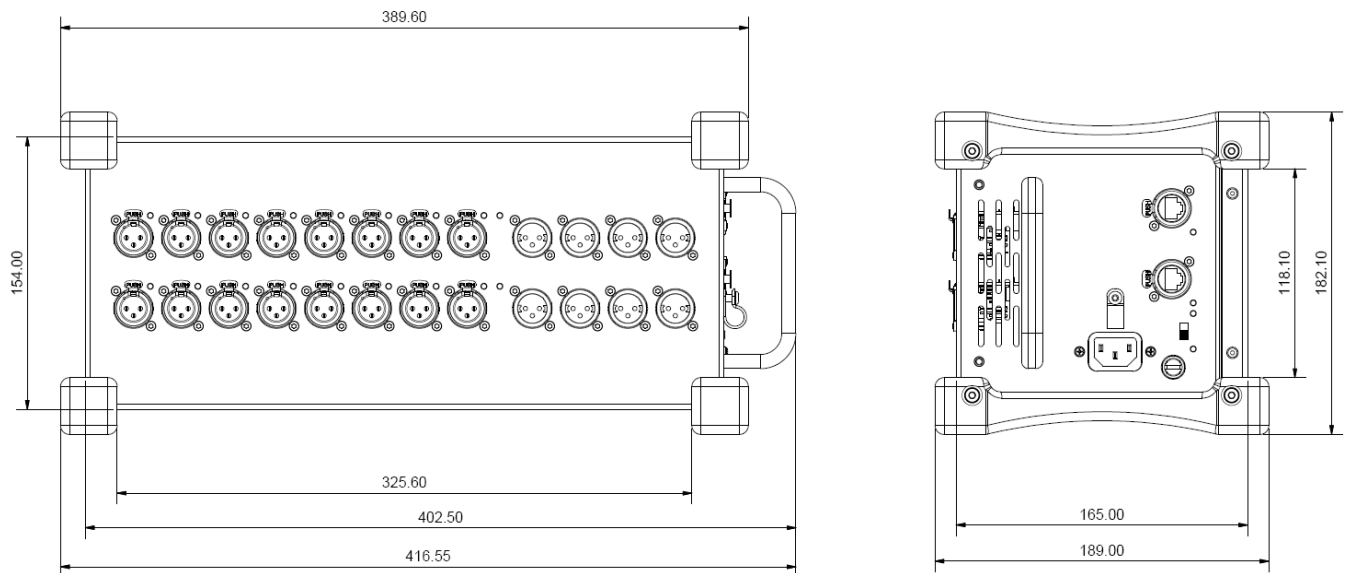

A&E Specifications

The unit shall be a portable remote audio device for Dante enabled Allen & Heath mixing systems. The remote audio unit shall provide 16 XLR inputs with individually configured Phantom Power and 8 XLR outputs. Phantom power LED indicators shall be provided per input socket on the remote audio rack. The unit shall be able to provide 48kHz or 96kHz sample rate on a Dante network.

Two Ethercon connectors shall be provided for transport of the digital audio and control signals over Dante. The unit shall be able to operate in 'redundant' or 'switched' mode by means of software. In 'redundant' mode the unit shall provide full redundant connection to any Dante enabled device. In 'switch' mode the unit shall allow daisy chained connection of multiple units. The unit shall have a hardware "Network reset" switch.

The Ethernet protocol shall provide control to the remote preamp, and all mic preamps shall be recallable by the mixing system.

The remote audio unit shall have a robust steel chassis and shall be designed to be portable and to be placed horizontally or vertically on the stage or performance environment.

A carrying handle shall be provided to facilitate lifting and holding the device when moving and an optional padded dust cover shall be available.

An optional 19" rack mounting kit shall be available.

The remote audio unit shall have a built-in power supply accepting AC mains voltages of 100~240V, 50/60 Hz, 40W max via an earthed 3-pin IEC male connector mounted on the rear chassis.

Recommended operating temperature for the remote audio unit shall be 0 to 40 degrees Celsius.

The unit shall be the Allen & Heath DT168.

System Specification

Mic/Line XLR Inputs	Balanced, +48V Phantom Power
Mic/Line Preamp	Fully recallable
Input Sensitivity	-60 to +15dBu
Analogue Gain	+5 to +60dB, 1dB steps
Pad	-20dB Active PAD
Maximum Input Level	+30dBu (PAD in)
Input Impedance	>4k Ω (Pad out), >10k Ω (Pad in)
Mic/Line Channel noise	22-22kHz, Direct Out @ unbalanced out
Mic EIN	-127dB with 150 Ω source
Unity gain (Pad in)	-90dBu
Low gain (5dB, Pad out)	-96dBu
Mid gain (30dB, Pad out)	-90dBu
Mic/Line Channel THD+N	22-22kHz, Direct Out @ unbalanced out
Unity gain (Pad in)	0.003% -88dBu @ 1kHz, 0dBu output
Low gain (5dB, Pad out)	0.002% -93dBu @ 1kHz, 0dBu output
Mid gain (30dB, Pad out)	0.003% -88dBu @ 1kHz, 0dBu output
Analogue XLR Outputs	Balanced, Relay protected
Output Impedance	<75 Ω
Nominal Output	+4dBu = 0dB meter reading
Maximum Output Level	+22dBu
Residual Output Noise	-92dBu (muted, 20-20kHz)
DANTE	
Sample rate	48kHz or 96kHz
Bit Depth	24 Bit
Gain, Pad, 48v Control	Allen & Heath dLive, Avantis, AHM-64 or SQ system
Operating Temperature	0 deg C to 40 deg C (32 deg F to 104 deg F)
Mains Power	100-240V, 50/60 Hz, 40W max
Dimensions and Weight	Width x Depth x Height x Weight 410mm x 190mm x 185mm x 4.6kg (16.1" x 7.5" x 7.3" x 10.1lbs)